

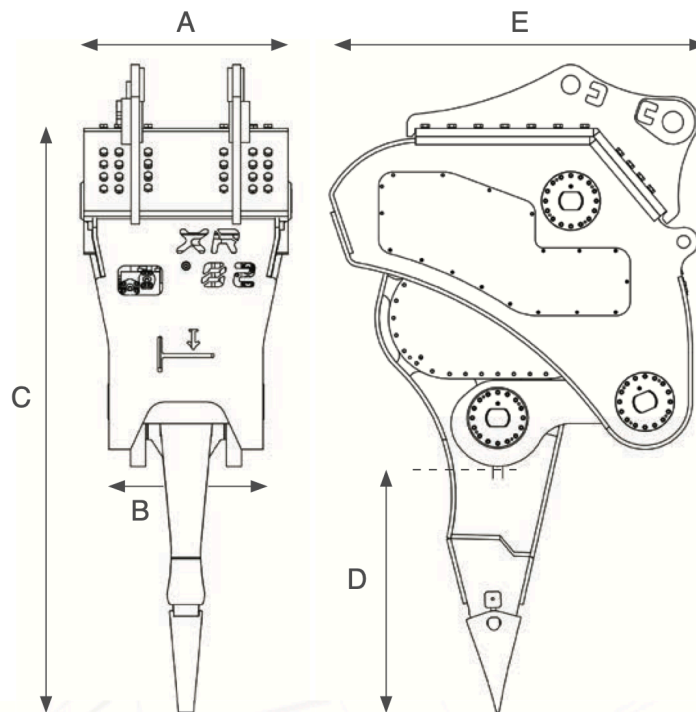

# XR 42



TECHNICAL SPECIFICATIONS		XR42
Excavator weight	Tons	32 - 40
Ripper operating weight (incl. top bracket)	kg	4.640
Ripper operating weight (top bracket not included)	kg	4.120
Hydraulic working pressure	MPa	24
Hydraulic oil flow	L/min	210
Frecuency	1/min	1.100



XR42	
<b>A</b>	860
<b>B</b>	630
<b>C</b>	2.865
<b>D</b>	1.215
<b>E</b>	1.715

\* Dimensions in millimeters.

**XCENTRIC RIPPER INTERNATIONAL, S.L.**

Arriurdina, 15 · 01015 Vitoria-Gasteiz (Spain) · Tel.: +34 945 290 555

[www.xcentricripper.com](http://www.xcentricripper.com)